



FASTASHADE Beach Patrol Shade (BPS) Assembly Instructions

Page 1

To Patrol Captains: If you do NOT fully understand these instructions, OHS advises that you DO NOT PUT UP THE BPS.

You can ring for assistance on:

0410 611 949 or 1800 818 421

For copies of these instructions and assembly videos visit

<http://www.beach-patrol-shade.com.au/> or

YouTube Channel Beach Patrol Shade

<https://www.youtube.com/watch?v=UL81t1-VpN4>

Important note:

Dig a hole 0.6m deep and .5m long.

Position peg in the hole at an angle

of 45°. Sand Peg must be

driven into hard sand with the

head 0.5m below the top sand level.

If the sand is too soft you may have to dig deeper to secure peg!!!

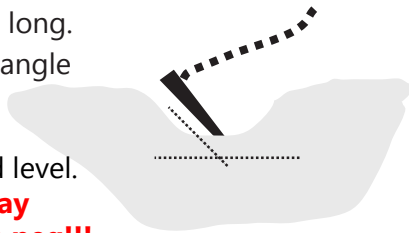

#1: Site setup - Aerial view

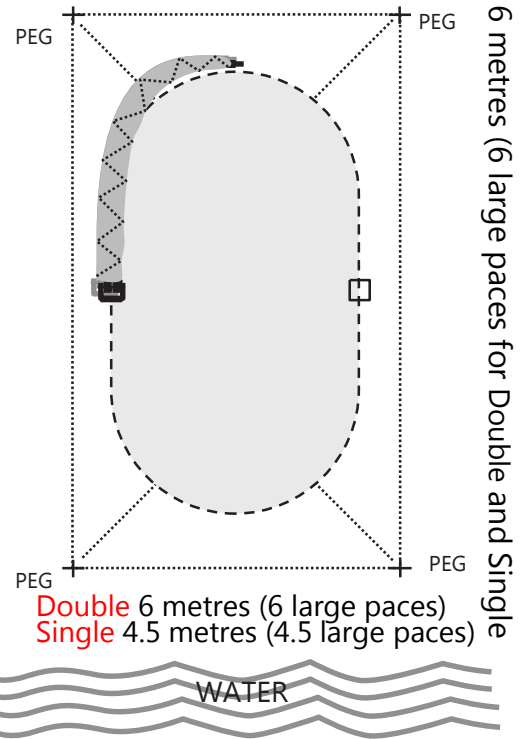

#2: Unpacking the BPS

Unwrap the J shaped BPS

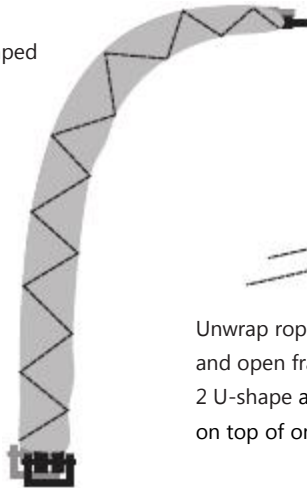

Unwrap ropes and open frame to 2 U-shape arches lying on top of one another

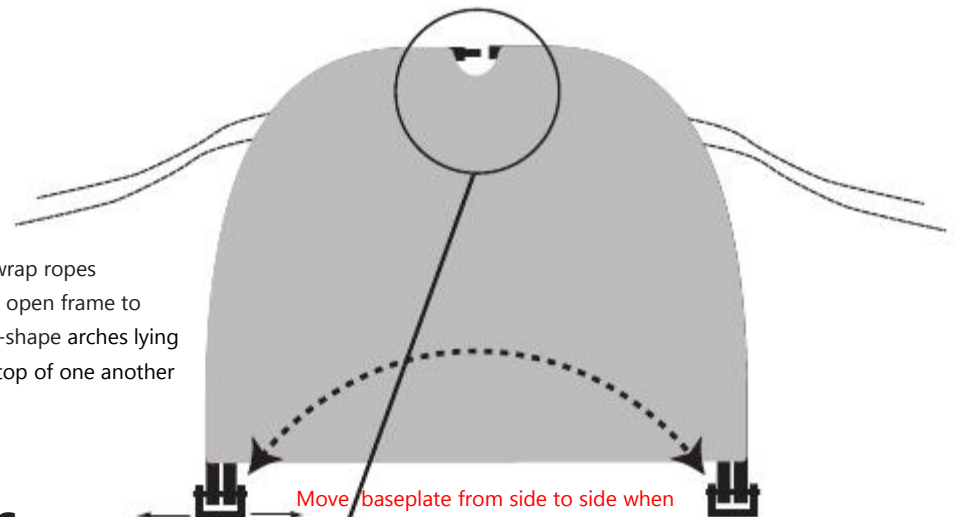

#3: Joining the arches

Two people should kneel at the top of the BPS frame and place one hand on the exposed pipe and the other on the fabric. Grab the fabric at arms length (near the saddle bracket) and pull to the top of the pipe (where the join is). Now pull the pipe ends apart until their edges meet. Another person can help line the sleeve and collar up by moving the base ends to & fro at the other end of the frame (see above). **Always keep the frame low and parallel to the ground.** Once you can see that the pipe ends are aligned allow the male and female collars to slide into each other. Four people can do this operation.

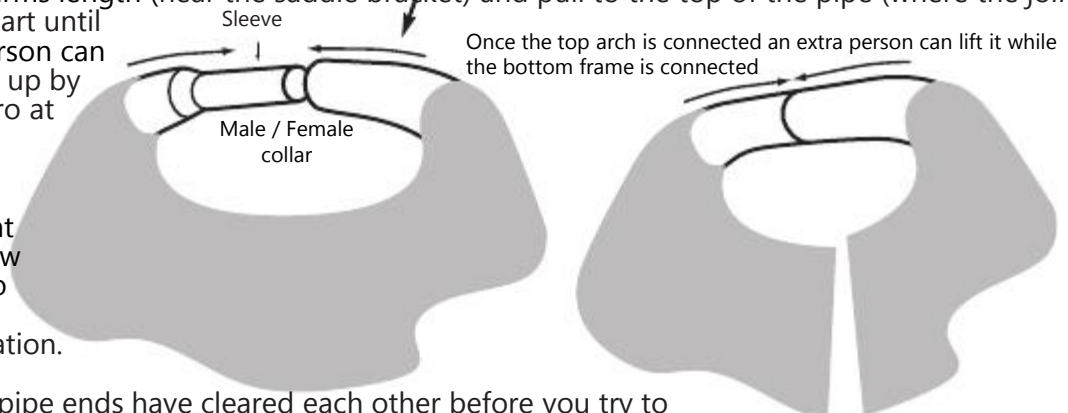

Note: Always make sure the pipe ends have cleared each other before you try to connect them, and never raise the male and female collar upwards in a "V" shape to create clearance!!



FASTASHADE

Beach Patrol Shade (BPS) Assembly Instructions Page 2

#4: Attaching guide ropes

IMPORTANT:

Attach ropes from saddle brackets of the lower U-shaped arch to sand pegs. Tie off with cleat and bury peg. Ensure you have approx 1/2 metre of rope loose.

NOTE: The sand pegs must be buried at the bottom of a sand pit with 0.5m of sand above the pegs head. Once secure (**and only then**) can step 5 be attempted.

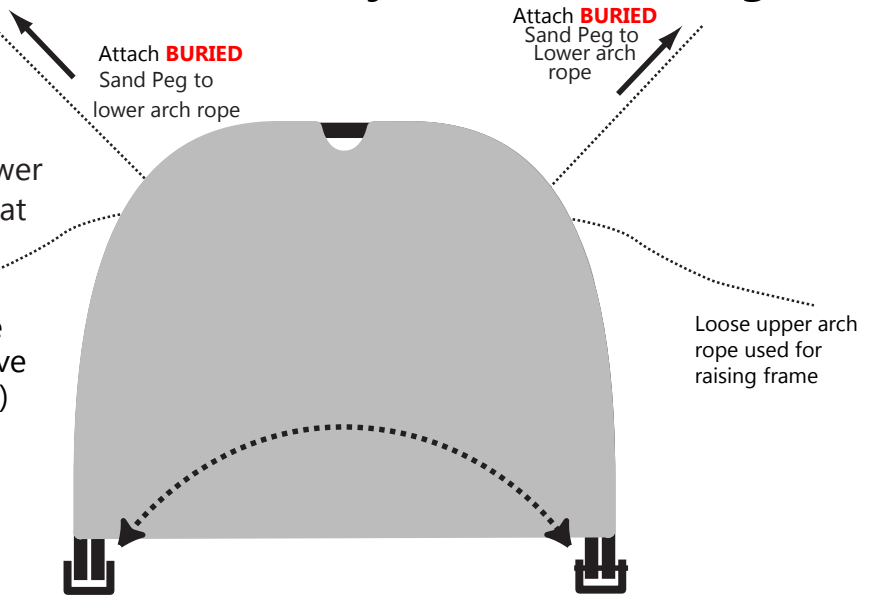

#5: Raising the BPS

Once 2 sand pegs have been anchored (**see #4**)

1 person should hold down the bottom arch (to prevent the BPS from sliding and help to lift the upper arch) while 2 people pull the guy ropes and raise the BPS.

When half lift is reached, release bottom arch!

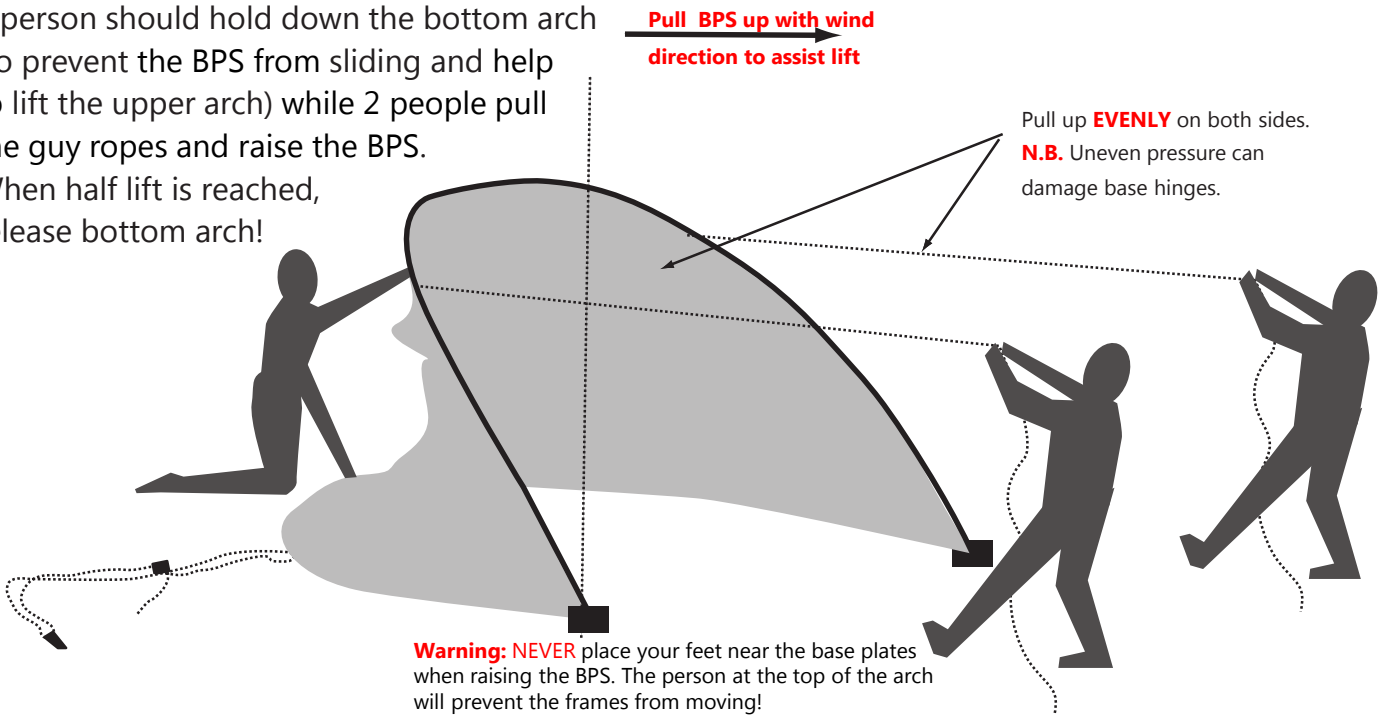

#6: Anchor ropes and Tightening the BPS

When BPS is upright and spread, attach ropes to the front set of pegs and bury in 0.5m of sand.

Tighten all 4 guide ropes to tension and balance BPS

Note: Unit must be tight at all times for optimum Performance

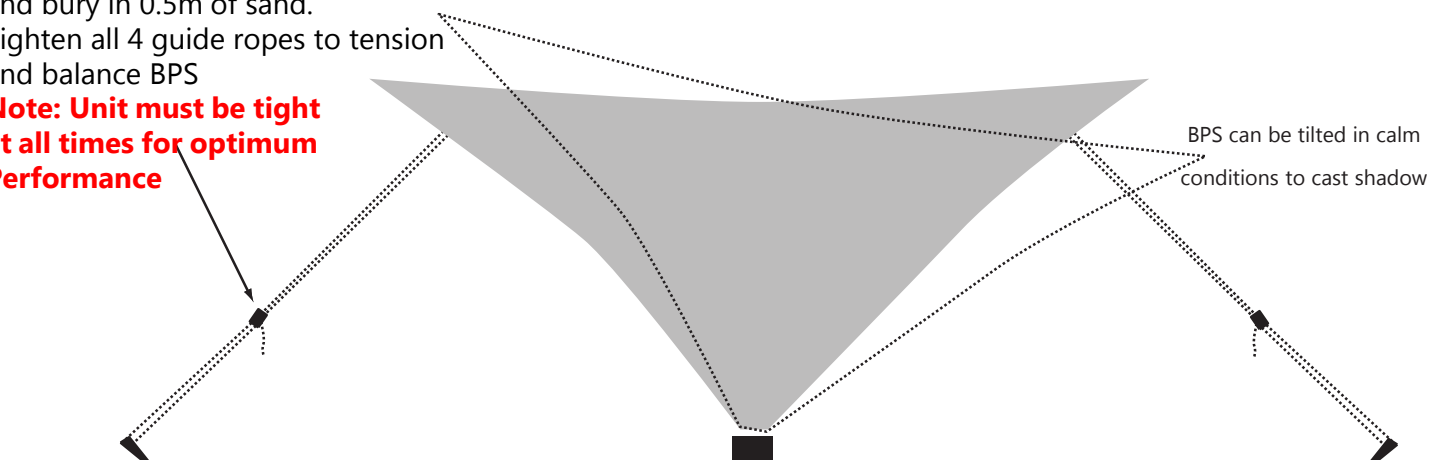



FASTASHADE

Beach Patrol Shade (BPS) Disassembly Instructions

#1: Release and lower

Drop BPS with wind direction to assist



Lower **EVENLY** on both sides.

Note: Uneven force can damage base hinge.

Unfasten 2 ropes at one end of the structure and allow it to lower down onto itself gradually

IMPORTANT

Do not unfasten ropes at the other end until the BPS is safely lying on the ground!!

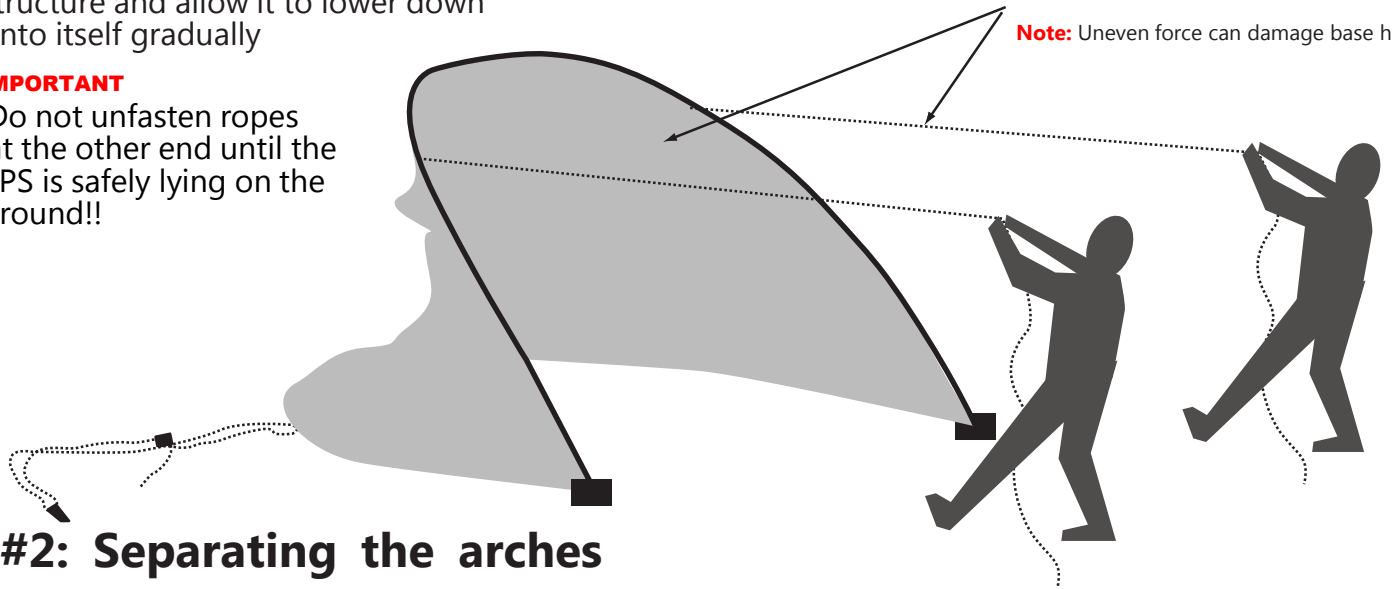

#2: Separating the arches

2 people should kneel at the top of the frame, gather the fabric from the saddle bracket and pull to the top of the pipe. (The fabric keeps the frame together. Once you release the pressure - the pipes can be pulled apart easily.) One more person should move the base plates to and fro until the tops of the pipes are in alignment. **Always keep the frame low and parallel to the ground. Do not stand in an attempt to get a better grip!**

If you concentrate your efforts on:

1. Releasing the fabric pressure
2. Correct alignment of the pipes

They will separate easily!

An extra person can help by raising the top frame while the other two separate the arches of the bottom frame

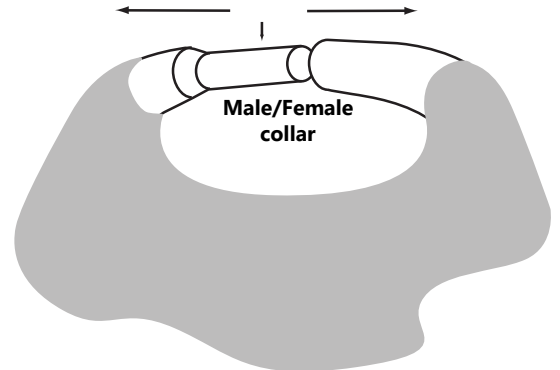
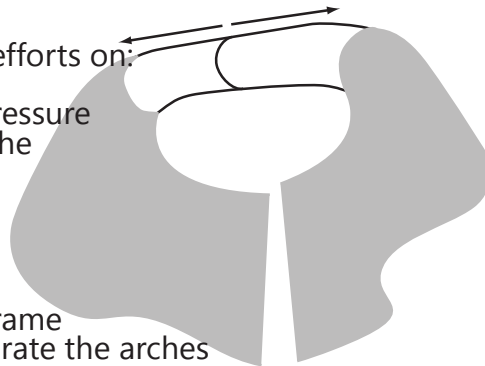

YouTube Channel Beach Patrol Shade

<https://www.youtube.com/watch?v=UL81t1-VpN4>

#3: Wrapping up the BPS

IMPORTANT: Only now can you unfasten the bottom two ropes.

Detach the 2 lower frame ropes from the pegs and pull out all 4 pegs.

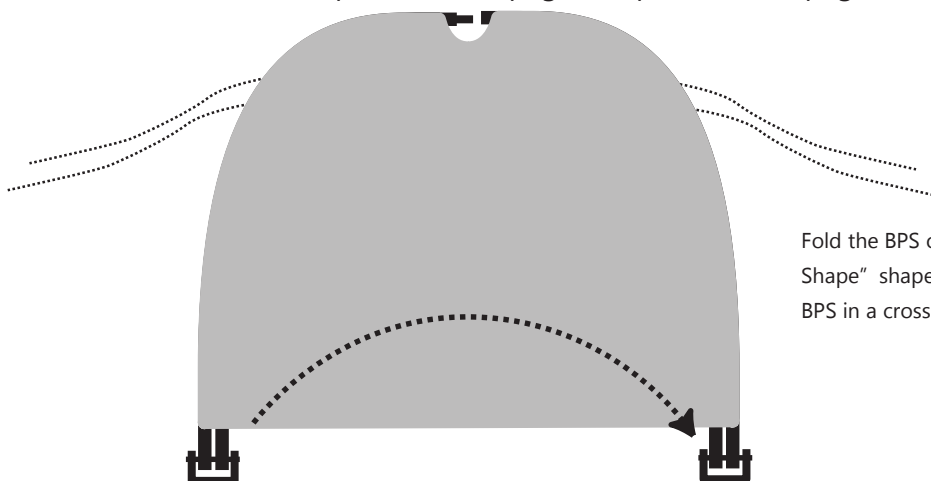

Fold the BPS over on itself to create a "J Shape" shape. Use the ropes to tie up the BPS in a cross-over pattern as shown.

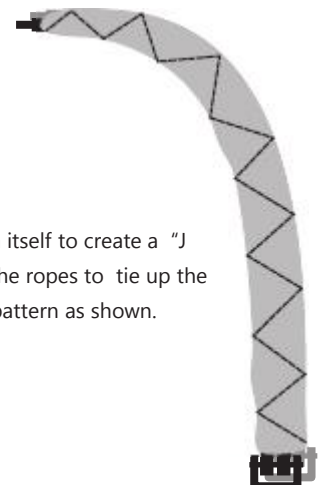

- Popular on YouTube
- Music
- Sports
- Gaming
- Education
- Movies

CHANNELS FOR YOU

- ClubhousesSportsFan
- PGA TOUR
- Bad Teeth
- danisnotonfire
- YouTube Spotlight

Browse channels

Sign in now to see your channels and recommendations!

Sign In



Beach Patrol Shade Home Page

Subscribe 0

Beach Patrol Shade

- Videos
- Discussion
- About

All activities

Beach Patrol Shade uploaded and posted

Customise your message



carshadebeachv1

1 month ago • 27 views

Beach Patrol Shade

Setup 8 mins...